



→ Arpa	2
Cosy Island	6
Cosy Curve	10
Cosy Outdoor	14
Minima 3.0	18
Pentagramma	22
Rock Table Mini	26
Rock Table Maxi	30
Carpets	34

Arpa

→ New

Designed by Ramón Esteve Estudio

Eng As its name implies, the Arpa collection is inspired by the Harp, one of the most beautiful and mesmerizing musical instruments. Unlike the meticulous work involved in manufacturing a harp, in designing this collection, rigorous paring down was applied, resolving each piece with the least possible number of elements.

Arpa collection combines the stability of the orthogonal external shape with the softness and comfort of the inner cushion shell. The thin strings add elegance and fineness to every piece, giving a special sense of lightness, as if the whole cushion mass was hanging from the structure.

Designed to be timeless, Arpa aims to become an icon, not only for aesthetic reasons, but also for its functionality and comfort.

Comfort and versatility characterise the Arpa modular system. Intermediate and corner solutions, with and without armrests, create different configurations for meeting and spending time in the open air.

Ita Come suggerisce il nome, la collezione Arpa si ispira allo strumento musicale, uno dei più belli e accattivanti. Contrariamente alla meticolosa lavorazione che prevede la fabbricazione di un'arpa, per il design della collezione è stato effettuato un rigoroso esercizio di sintesi, risolvendo ogni pezzo con il minor numero possibile di elementi.

Arpa combina la stabilità della struttura ortogonale esterna con il comfort e la morbidezza del cuscino interno. Le raffinate corde aggiungono eleganza e delicatezza ad ogni elemento della famiglia donando una sensazione di leggerezza, come se l'intero rivestimento galleggiasse sospeso dalla propria struttura.

Progettato per essere senza tempo, Arpa intende diventare un'icona, non solo per motivi estetici, ma anche per funzionalità e comfort.

Comfort e versatilità caratterizzano il sistema modulare Arpa. Le soluzioni intermedie e angolari, con braccioli e senza braccioli danno vita a diverse configurazioni dove incontrarsi e stare all'aria aperta.



		 INDOOR / OUTDOOR	
Armchair L102 D87 H70 seat H45 D84	End units L/R L197 D87 H70 seat H45 D84	3S sofa L220 D87 H70 seat H45 D84	Intermediate units L87 D87 H70 seat H45 D84
Side table L87 D87 H27	Pouf L87 D87 H43	Backrest cushions L84 D40 H20 L100 D40 H20	Additional cushions L40 D40 H20 L45 D45 H20 L55 D55 H20
Outdoor covering tarpaulin armchair, intermediate unit 87×102 3S sofa 87×220 End unit 87×197 side table 87×87 pouf 87×87			

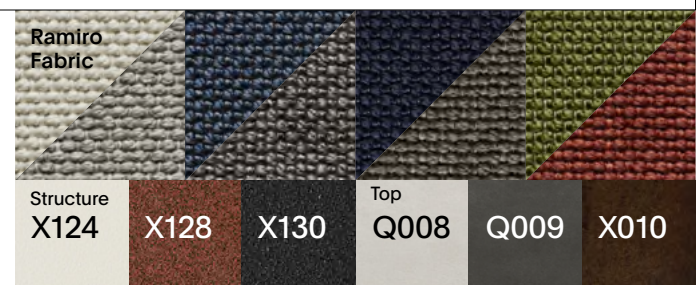





Cosy Island

→ New

Eng The timeless lines, soft and all embracing design, adaptability and versatile character make Cosy a padded item that offers the utmost comfort in a wide range of situations, environments and frameworks.

Rota carries the most classic of the MDF Italia padded elements, Cosy sofa, towards a style inspired by soft lines and even warmer. In addition to the existing modules characterised by seats of different depths and lengths and the newest island elements, a new version with a curved base and backrest is added, ideal for creating ideal to create an atmosphere of conviviality thanks to its dialoguing faces.

Cosy Curve becomes the natural centre of gravity around which the fluid spaces of the modern home, or the large open space of the office and hospitality world rotate, the sinuous proportions of the seats and the curved line of the sofa offer a pleasant feeling of cosiness and comfort.

Designed by Francesco Rota

Ita Il segno senza tempo, il disegno morbido ed avvolgente, la sua adattabilità e versatilità, rendono Cosy un imbottito capace di offrire grande comfort in situazioni, ambienti e contesti differenti.

Francesco Rota traghetta il divano Cosy, verso un linguaggio di linee ancora più morbide.

Ai moduli esistenti caratterizzati da sedute di differenti profondità e lunghezze e ai più recenti elementi a isola si aggiunge un'inedita versione caratterizzata da basamento e schienale curvi, ideale per creare un'atmosfera di convivialità grazie alle sue facce dialoganti.

Pensato per divenire il naturale baricentro attorno cui si sviluppano gli spazi fluidi della casa moderna o i grandi open space del mondo office e hospitality, le proporzioni delle sedute di Cosy Island e la linea curva di Cosy Curve offrono una piacevole sensazione di accoglienza e di comodità.



Seating module Island S L85 D85 H40	Seating module Island M L125 D85 H40	Seating module Island L L170 D85 H40	Seating module Island XL L210 D85 H40	Seating module Island L - extra L170 D125 H40	
One-sided backrest L85 only for Island modules L85 D33 H66	One-sided backrest L125 only for Island modules L125 D33 H66	One-sided backrest L170 only for Island modules L170 D33 H66	Two-sided backrest L85 only for Island modules L85 D38 H66	Two-sided backrest L125 only for Island modules L125 D38 H66	Two-sided backrest L170 only for Island modules L170 D38 H66





Cosy Curve

→ New

Eng The timeless lines, soft and all embracing design, adaptability and versatile character make Cosy a padded item that offers the utmost comfort in a wide range of situations, environments and frameworks.

Rota carries the most classic of the MDF Italia padded elements, Cosy sofa, towards a style inspired by soft lines and even warmer. In addition to the existing modules characterised by seats of different depths and lengths and the newest island elements, a new version with a curved base and backrest is added, ideal for creating an atmosphere of conviviality thanks to its dialoguing faces.

Cosy Curve becomes the natural centre of gravity around which the fluid spaces of the modern home, or the large open space of the office and hospitality world rotate, the sinuous proportions of the seats and the curved line of the sofa offer a pleasant feeling of cosiness and comfort.

Designed by Francesco Rota

Ita Il segno senza tempo, il disegno morbido ed avvolgente, la sua adattabilità e versatilità, rendono Cosy un imbottito capace di offrire grande comfort in situazioni, ambienti e contesti differenti.

Francesco Rota traghetta il divano Cosy, verso un linguaggio di linee ancora più morbide.

Ai moduli esistenti caratterizzati da sedute di differenti profondità e lunghezze e ai più recenti elementi a isola si aggiunge un'inedita versione caratterizzata da basamento e schienale curvi, ideale per creare un'atmosfera di convivialità grazie alle sue facce dialoganti.

Pensato per divenire il naturale baricentro attorno cui si sviluppano gli spazi fluidi della casa moderna o i grandi open space del mondo office e hospitality, le proporzioni delle sedute di Cosy Island e la linea curva di Cosy Curve offrono una piacevole sensazione di accoglienza e di comodità.

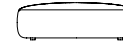
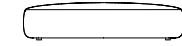
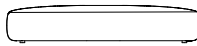
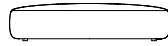
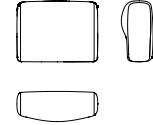
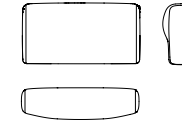
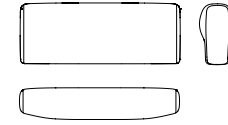
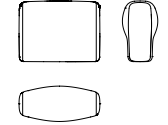
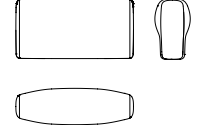
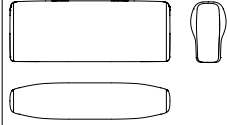
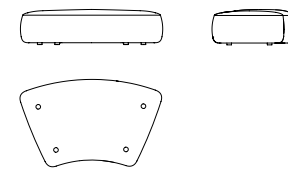
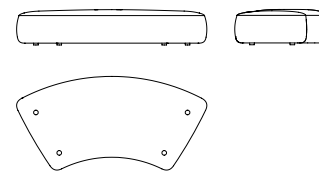
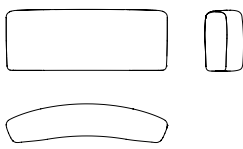

Seating module Island S L85 D85 H40 	Seating module Island M L125 D85 H40 	Seating module Island L L170 D85 H40 	Seating module Island XL L210 D85 H40 	Seating module Island L - extra L170 D125 H40 	
One-sided backrest L85 only for Island modules L85 D33 H66 	One-sided backrest L125 only for Island modules L125 D33 H66 	One-sided backrest L170 only for Island modules L170 D33 H66 	Two-sided backrest L85 only for Island modules L85 D38 H66 	Two-sided backrest L125 only for Island modules L125 D38 H66 	Two-sided backrest L170 only for Island modules L170 D38 H66 
Seating module Curve S L155 D85 H40 		Seating module Curve M L205 D85 H40 		one-sided backrest only for Curve modules L175 D33 H66 	



Cosy Outdoor

→ New

Designed by Francesco Rota

Eng The family of the Cosy sofa, designed by Francesco Rota in 2017, continues to expand. Its strength lies in its modularity, which makes it extremely adaptable to the environment and flexible, not only in terms of configurations but also in terms of use.

And so, in its evolved form, it is also now designed to furnish open-air spaces, both in the residential and contract and hospitality worlds, with upholstery materials suitable for outdoor use. The distinguishing feature of the outdoor proposal is found in the painted stainless steel structures behind the backrest, which both supports and embellishes the seat.









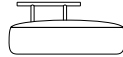

The load-bearing seat structure and back frame in epoxy powder coated stainless steel. The seat frame has elastic straps specific for outdoor use, padding in differentiated density polyurethane foam and fixed covers in polyester bonded with water-repellent canvas that seals the cushion and makes it completely waterproof. The cushions are completely upholstered with removable fabric covers.

Ita Continua a espandersi la famiglia del divano Cosy, concepito da Francesco Rota nel 2017. La modularità è la sua forza che lo rende estremamente adattivo all'ambiente e flessibile non solo in termini di configurazioni ma anche d'uso.

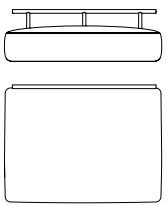
Ed ecco che nella sua evoluzione viene immaginato ora per arredare gli spazi all'aria aperta, sia in ambito residenziale sia legato al mondo del contract e dell'hospitality, con materiali di rivestimento idonei all'utilizzo in esterno. Il tratto distintivo della proposta outdoor si ritrova nelle strutture in acciaio inox verniciato che si collocano sul retro dello schienale, e svolgono al contempo una funzione di sostegno e decorativa.

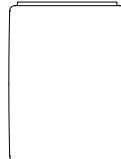
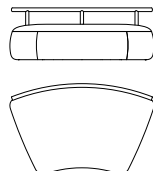
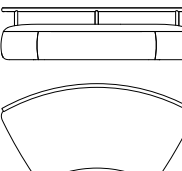
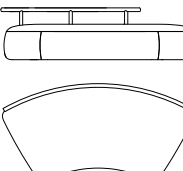
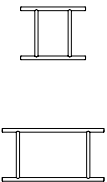
Struttura portante del sedile realizzata in acciaio inox, verniciata a polveri epossidiche. Il telaio del sedile è dotato di cinghie elastiche ad uso specifico esterno. Il telaio dello schienale è in acciaio inox, verniciato a polveri epossidiche. Imbottitura in poliuretano espanso a densità differenziata e rivestimento in fodera fissa di poliestere accoppiato con tela idrorepellente, che sigilla e rende completamente impermeabile il cuscino. Il rivestimento in tessuto ricopre la cuscina-tura in ogni sua parte, ed è completamente removibile.

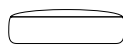
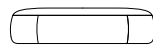
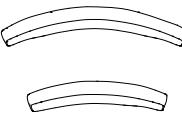

 <small>INDOOR / OUTDOOR</small>						
S module L70 backrest L85 D87 H59 seat H41 	M module L70 backrest L/R L125 D87 H59 seat H41 	M module L110 backrest L125 D87 H59 seat H41 	L module L110 backrest L/R L170 D87 H59 seat H41 	L module L155 backrest L170 D87 H59 seat H41 	Deep L module L155 backrest L170 D127 H59 seat H41 	
Deep L module L110 backrest L127 D170 H59 seat H41 		Deep L module L155 backrest L155 D87 H59 seat H41 	Deep L module L155 backrest L205 D87 H59 seat H41 D170 	Deep L module L110 backrest L/R L205 D87 H59 seat H41 	Armrest L/R L70 H57 L110 H57 	
Single module L85 D87 H41 	Single module L125 D85 H41 	Single module L155 D85 H41 	Back cushions L140, 200 D25 	Curve back cushions L100 D25 	Additional cushions L40 D40 L45 D45 L55 D55 	





Minima 3.0

→ New

Eng An MDF Italia classic since its conception and the collection's modular system par excellence, Minima 3.0 now sees the addition of a new storage unit that brings this historic shelving bang up to date and in line with new architectonic and contemporary living styles. Formality, minimalism, careful details and new finishes are the signature features confirmed and innovated in the new units added to the existing ones.

The door is further enhanced by two main materials: rear-lacquered glass and grooved Cimento®. The development of this new unit has brought about a new partnership between MDF Italia and Cimento®.

Cimento® is a revolutionary concrete compound that, when applied to different media, gives a solidly consistent appearance to surfaces and surprising texture.

Robust tradition here teams with the minimalism of modern taste to generate unique projects. These are the fundamental elements and characteristics that have united the two companies, leading to unique collaboration.

Metrica designed by Bruno Fattorini

Ita Minima 3.0 da sempre un classico MDF Italia e sistema componibile per eccellenza della collezione, si arricchisce con l'evoluzione di un nuovo contenitore che rende la storica libreria al passo dei tempi e in linea con nuovi stili architettonici e abitativi contemporanei. Rigore, essenzialità, ricerca del dettaglio e di nuove finiture sono gli emblemi che vengono confermati e rinnovati nei nuovi contenitori proposti e che si affiancheranno a quelli esistenti.

L'anta si arricchisce principalmente di due materiali: vetro retrolaccato e cemento ordito (Cimento®).



Con lo sviluppo del nuovo contenitore, nasce una nuova collaborazione tra MDF Italia e Cimento.

Cimento è un composto cementizio rivoluzionario, che applicato a vari supporti, consente di ottenere un aspetto della superficie solida, materica e capace di sorprendere con le sue texture.

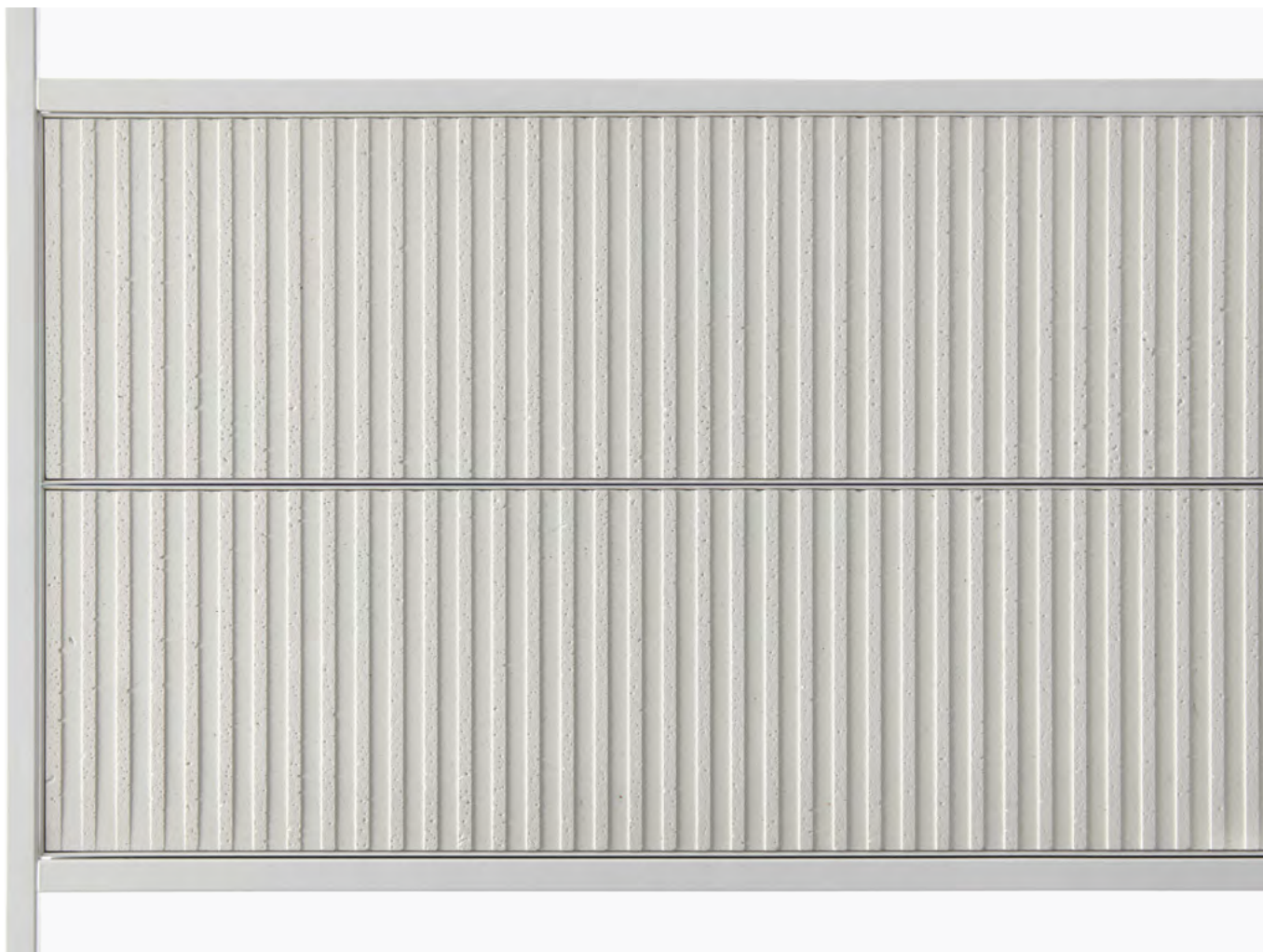
Concretezza della tradizione si fonde con l'essenzialità del gusto moderno per dare origine a progetti unici. Questi sono elementi e caratteristiche fondamentali che hanno unito le due realtà aziendali e portato a una collaborazione unica.



→ Technical details

	
Cabinet with flap opening door L60, 90, 120 D33 H35	
	
Cabinet with two drawers L60, 90, 120 D33 H35	
	
Fronts X150	X151
X152	X153
X011	X012
X148	X149





Pentagramma

designed by Pitsou Kedem

→ New

Eng Pentagramma is the new living system designed by Pitsou Kedem for MDF Italia, a design with a strong personality that interprets the concept of the day system with sophistication by focusing on the value of lightness.

Surprisingly simple to compose and install, the design develops from an extruded aluminium panel fixed to the wall, on which various elements, containers or shelves are hung. Its name was inspired by its construction: the wall-mounted back panel to which the accessories are hung to create the composition looks like a music stave or pentagramma in Italian, on which the notes are written to compose a tune.

Extremely flexible and versatile, this system offers the possibility of reconfiguring the layout over time. Just a few elements are enough to obtain infinite combinations that fulfil different functions and situations of use, fitting seamlessly and with versatility into all residential and contract environments: in fact, it offers a valid storage solution for walls in the living area and office, but also for creating compositions in the sleeping area.













Ita Pentagramma è il nuovo sistema giorno firmato by Pitsou Kedem per MDF Italia, progetto fortemente identitario che interpreta in maniera sofisticata il concept di sistema giorno mettendo al centro il valore della leggerezza.

Caratterizzato da una sorprendente semplicità compositiva e d'installazione, il progetto si sviluppa a partire da un pannello in estruso di alluminio vincolato al muro, al quale si agganciano in sospensione diversi elementi, vani a giorno o mensole. Ed è proprio la sua costruzione ad averne ispirato il nome: lo schienale a muro su cui si applicano gli accessori per creare la composizione ricorda un pentagramma su cui si scrivono le note per comporre una melodia.

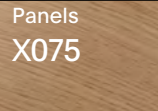
Estremamente flessibile e versatile, questo sistema offre la possibilità di riconfigurare il layout nel tempo. Pochi elementi sono sufficienti per ottenere infinite combinazioni che assolvano diverse funzioni e situazioni d'uso, declinandosi in maniera trasversale a tutti gli ambienti residenziali e contract: rappresenta infatti una valida soluzione per attrezzare pareti nella zona giorno e in ufficio, ma anche per dare vita a composizioni nella zona notte.

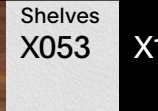
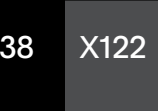

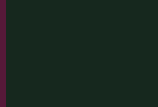
→ Technical details

			
Panels L150, 200, 250 H33.3 	Shelves L60, 90, 120 H33.4 		
Shelves with L/R divider L120 H33.4 	Open cabinets with L/R divider L90 D30.6 H34.2 		
Open cabinets L30, 60 D30.6 H34.2 			
Panels X075 	Shelves X053 	X138 	X122 
Cabinets 			





Rock Table Mini

→ New

Eng The Rock Table family also includes the Mini Rock Tables: coffee tables with a strong personality, in which the lines of the collection are appropriately reproporioned to create furnishing accessories for the indoor or outdoor living space. These tables come with tops in three different heights and sizes, a trio useful for creating a wide range of compositions.

Designed by Jean Marie Massaud

Ita Dalla famiglia Rock Table nascono i Rock Table Mini: coffee table dalla forte personalità, in cui le linee della collezione sono opportunamente riproporzionate per realizzare complementi d'arredo a corredo del living indoor, oppure outdoor. I tavolini vengono proposti in tre differenti altezze e dimensioni di top, un tritico utile per creare svariate composizioni.



→ Technical details

Tables with cement top and stone chip cement top are also suitable for outdoor.			
H39 Table H39 Ø140	H46 Table H46 Ø 80		
H60 Table H60 Ø 80	Outdoor covering tarpaulin H73 Ø80, 100, 120		

Top	X042	X082	X075	X076	
			Q058	Q057	Q059
Base	X080	X081	Q061	Q060	





Rock Table Maxi

→ New

Eng The new model Rock Table Maxi features a top with an unusual and interesting shape: a rectangle with rounded corners with a physiognomy that fosters a direct relationship among those sitting around the table, facilitating interaction and dialogue.

The lightened concrete base supports a new, lightweight wooden top in bleached or brown-stained oak and Canaletto walnut, for the indoor version and a top in lightened concrete for the outdoor version. A style that combines radicality and sensuality, softness and boldness, and complements modern home environments as well as lounges, offices, rooms for entertaining or meeting people, where it leaves its own unique, bold mark.

Designed by Jean Marie Massaud

Ita Il nuovo modello, Rock Table Maxi, presenta un top dalla forma inusuale e interessante: un rettangolo dagli angoli smussati che per la sua fisionomia consente un rapporto diretto tra chi siede attorno al tavolo, facilitando l'interazione e il dialogo.

Il basamento in cemento alleggerito sostiene un inedito e leggero top in legno di rovere sbiancato, tinto marrone e noce canaletto, per la versione indoor, e un top in cemento alleggerito per la versione outdoor. Uno stile che unisce radicalità e sensualità, morbidezza e audacia, e si sposa a moderni ambienti domestici così come a lounge, uffici, stanze di rappresentanza o sale riunioni, dove porta un segno unico e deciso.

→ Technical details

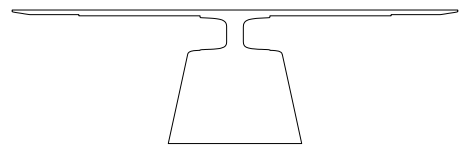
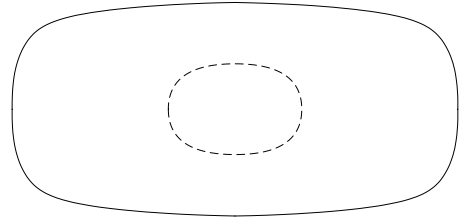
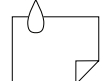
	Tables with cement top and stone chip cement top are also suitable for outdoor.	
<p>Base L72 D49</p> 		
<p>Table top L210 D105 H73 L240 D115 H73</p> 		
<p>Outdoor covering tarpaulin H73 L210, 240</p> 		

Top X042	X082	X075	X076	
		Q058	Q057	Q059
Base X080		X081	Q061	Q060



Carpets

→ New

designed by
Valentina Cameranesi, Enrico Pompili

Eng The Tatami collection, design by Valentina Cameranesi and Enrico Pompili, reinterprets the classic carpet in a contemporary key, suggesting an approach based on alternating Japanese-inspired graphics. Conceived in a neutral nuance, Tatami blends the essentiality of geometric shapes with refined elegance.

Made in Nepal from wool and bamboo silk - an innovative yarn of natural origin - Tatami with its graphic signs fits perfectly into contemporary interiors.

The Frammenti collection, designed by the Cameranesi Pompili duo, is the perfect mix of creativity and craftsmanship. The result of an artisanal weaving technique, the collection is characterised by a design inspired by fragments of paper in different tones that compose a collage that plays on different shades of red or delicate neutral nuances, creating fascinating depth effects.

A carpet with a contemporary spirit that recalls the traditional values of Nepalese weaving.

Ita La collezione Tatami, disegnata da Valentina Cameranesi ed Enrico Pompili, reinterpreta in chiave contemporanea il classico tappeto, suggerendo un approccio basato sull'alternanza grafica di ispirazione giapponese. Concepito in una nuance neutra, Tatami fonde l'essentialità delle forme geometriche con raffinata eleganza.

Realizzato in Nepal con filati in lana e seta di bambù - innovativo filato di origine naturale - Tatami con i suoi segni grafici si inserisce perfettamente negli interni contemporanei.

La collezione Frammenti, disegnata dal duo Cameranesi Pompili, è il perfetto mix tra creatività e lavorazione manuale. Risultato di una tecnica artigianale di tessitura, la collezione è caratterizzata da un disegno ispirato a frammenti di carta di diverse tonalità che compongono un collage che gioca sulle diverse sfumature del rosso o su delicate nuances neutre, creando affascinanti giochi di profondità.

Un tappeto dallo spirito contemporaneo che richiama i valori tradizionali della tessitura nepalese.

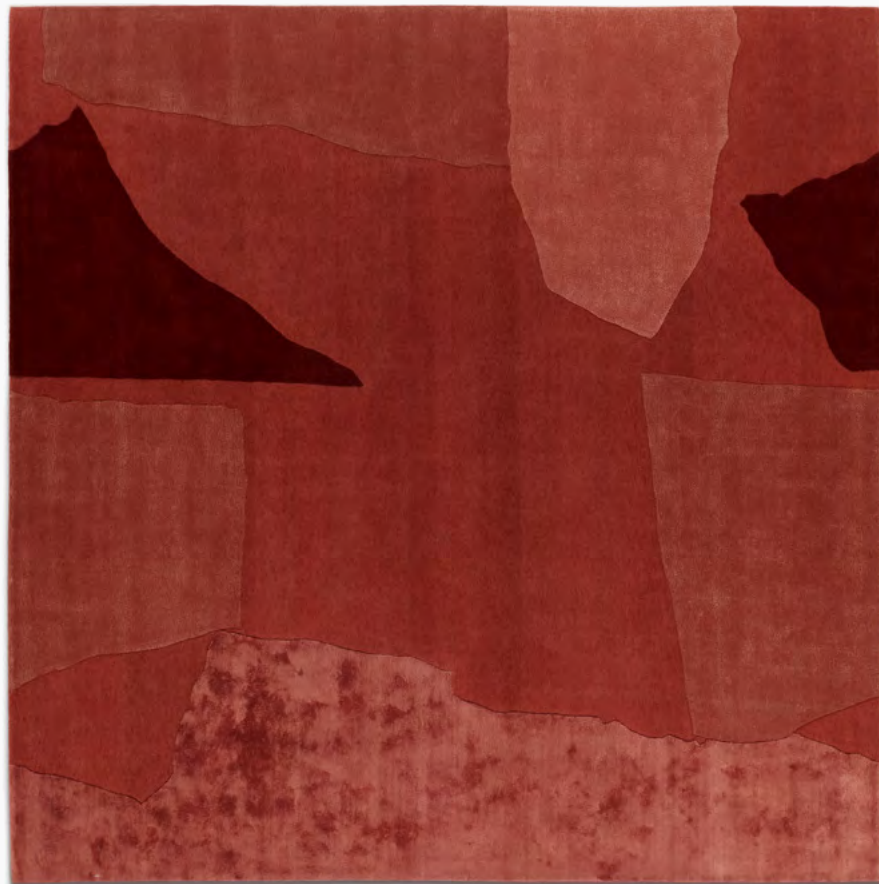

Tatami
L230 D300
L300 D400

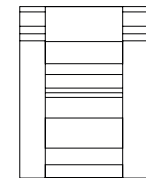

Frammenti
L230 D300
L300 D400

